



515 N. FRALEY STREET
KANE, PA 16735
PH. (814) 837-6464

VAN GUARD II ALUMINUM HURRICANE BARRIER OUTSWING "IMPACT"

GENERAL NOTES

1. This product has been evaluated and is in compliance with the 6th Edition (2017) Florida Building Code (FBC) structural requirements excluding the "High Velocity Hurricane Zone" (HVHZ).
2. Product anchors shall be as listed and spaced as shown on details. Anchor embedment to base material shall be beyond wall dressing or stucco.
3. When used in areas requiring wind borne debris protection, this product complies with FBC Sections 1609.1.2 & R301.2.1.2 and does not require an impact resistant covering. This product meets missile level "D" and includes Wind Zone 4 as defined in ASTM E1996 and FBC Sections 1609.1.2.2 & R301.2.1.2.1.
4. Site conditions that deviate from the details of this drawing require further engineering analysis by a licensed engineer or registered architect.

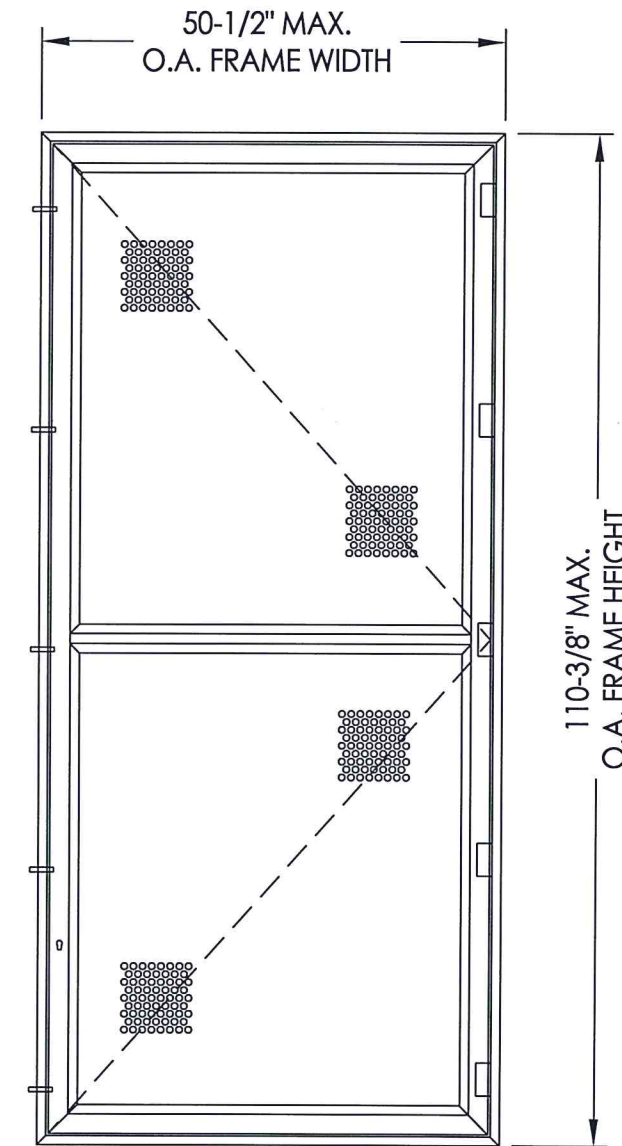
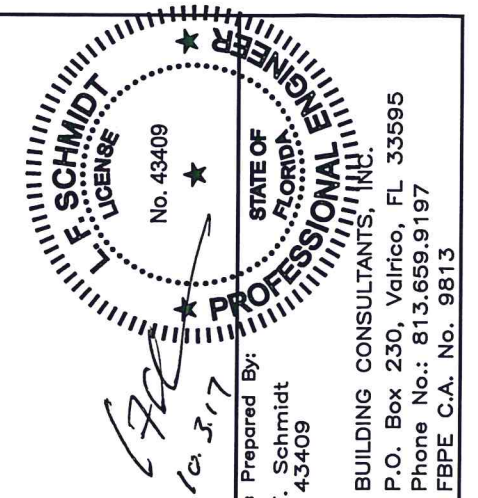

TABLE OF CONTENTS	
SHEET #	DESCRIPTION
1	Typical elevation, design pressures & general notes
2	Barrier panel sections, components & screen details
3	Reveal mount sections - masonry wall
4	Surface mount sections - masonry wall
5	Reveal mount sections - 2x wood framing
6	Surface mount sections - 2x wood framing
7	Surface mount anchoring - masonry wall
8	Reveal mount anchoring - masonry wall
9	Surface mount anchoring - 2x wood framing
10	Reveal mount anchoring - 2x wood framing
11	Components and hardware details
12	Bill of materials & lock release options

MOUNTING STYLE	OVERALL FRAME DIMENSION	SCREEN OPENING DIMENSION	DESIGN PRESSURE (PSF) (without Porosity Factor)		DESIGN PRESSURE (PSF) (with Porosity Factor*)	
			POSITIVE	NEGATIVE	POSITIVE	NEGATIVE
REVEAL MOUNT	50.50"	41.78"	70.0	70.0	110.0	110.0
SURFACE MOUNT	110.375"	49.18"	70.0	70.0	110.0	110.0

* NOTE: The Design Pressure shown has been increased for the porosity of the barrier (62%). The consideration of the use of the porosity factor is at the discretion of the Design Professional or the Authority Having Jurisdiction.



Documents Prepared By:
Lyndon F. Schmidt
P.E. No. 43409
R.W. BUILDING CONSULTANTS, INC.
P.O. Box 230, Valrico, FL 33595
Phone No.: 813.659.9197
FBPE C.A. No. 9813

PRODUCT: KANE SCREENS
VAN GUARD II
ALUMINUM HURRICANE BARRIER
PART OR ASSEMBLY:
TYPICAL ELEVATION, DESIGN PRESSURES & GENERAL NOTES

NO.	DATE	REVISIONS
3	9/26/17	UPDATE TO 6TH ED. (2017) FBC
2	7/01/15	UPDATE TO 5th ED. (2014) FBC
1	12/10/13	ADDED POROSITY D.P. RATING

DATE: 8/26/13
SCALE: N.T.S.
DWG. BY: JK
CHK. BY: LFS
DRAWING NO.: FL-10238.2
SHEET 1 OF 12

R:\Clients\Kane PERMANENT\A - Florida Product Approvals\FL-10238C - Drawings\FL-10238.1-2.dwg, 2.2

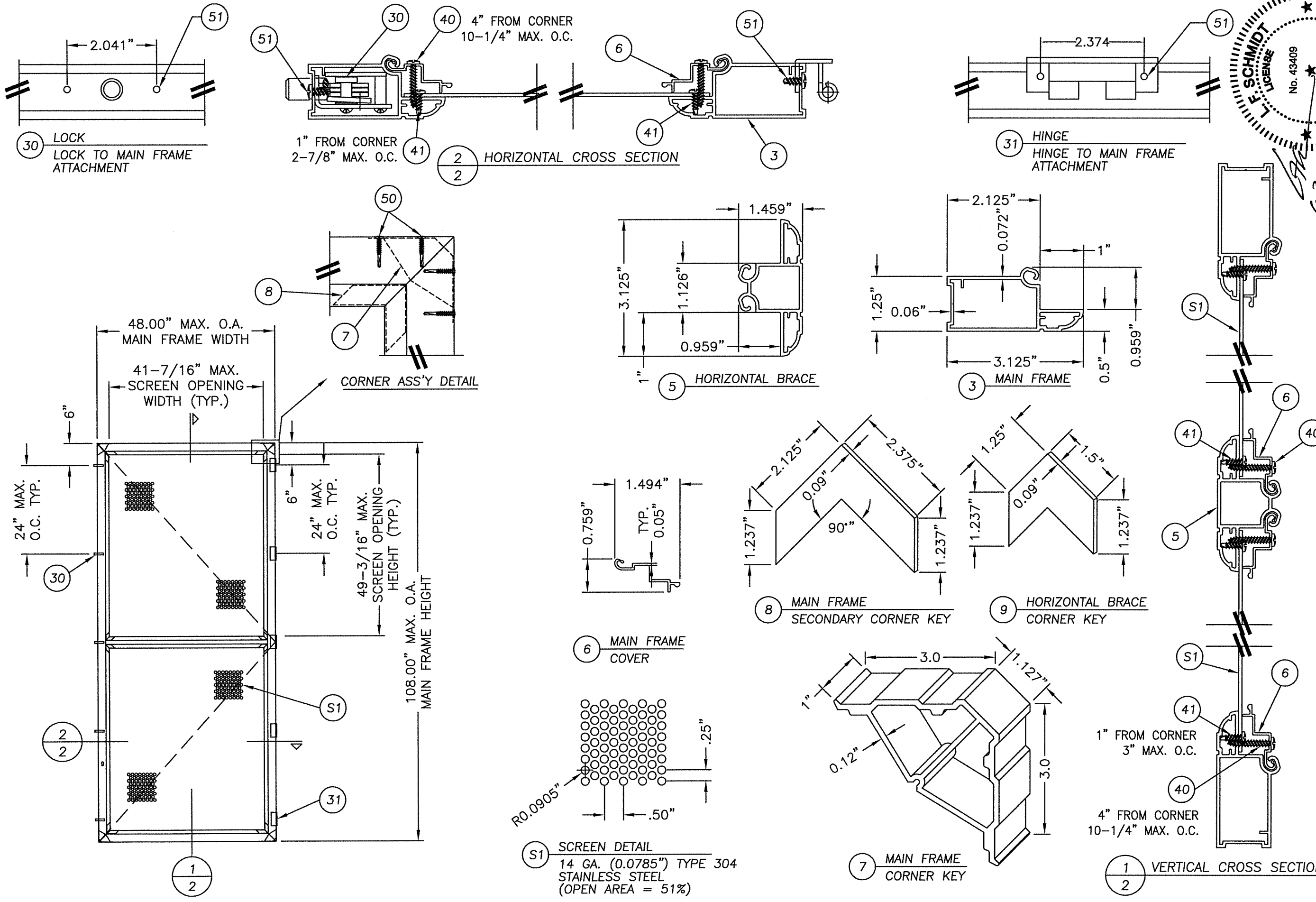

Lyndon F. Schmidt
 P.E. No. 43409
 No. 43409
 STATE OF FLORIDA
 PROFESSIONAL ENGINEER
 BUILDING CONSULTANTS, INC.
 P.O. Box 230, Valrico, FL 33595
 Phone No.: 813.659.9197
 FBPE C.A. No. 9813

Documents Prepared By:
 Lyndon F. Schmidt
 P.E. No. 43409
 R.W. BUILDING CONSULTANTS, INC.
 P.O. Box 230, Valrico, FL 33595
 Phone No.: 813.659.9197
 FBPE C.A. No. 9813

PRODUCT: KANE SCREENS VAN GUARD II
 ALUMINUM HURRICANE BARRIER
 PART OR ASSEMBLY:
 BARRIER PANEL SECTIONS,
 COMPONENTS & SCREEN DETAILS

NO.	DATE	BY	REVISIONS
3	9/26/17	JK	UPDATE TO 6TH ED. (2017) FBC
2	7/01/15	LFS	UPDATE TO 5th ED. (2014) FBC
1	12/10/13	LFS	ADDED POROSITY D.P. RATING

DATE: 8/26/13
 SCALE: N.T.S.
 DWG. BY: JK
 CHK. BY: LFS
 DRAWING NO.: FL-10238.2
 SHEET 2 OF 12

© 2013 R.W. BUILDING CONSULTANTS INC.

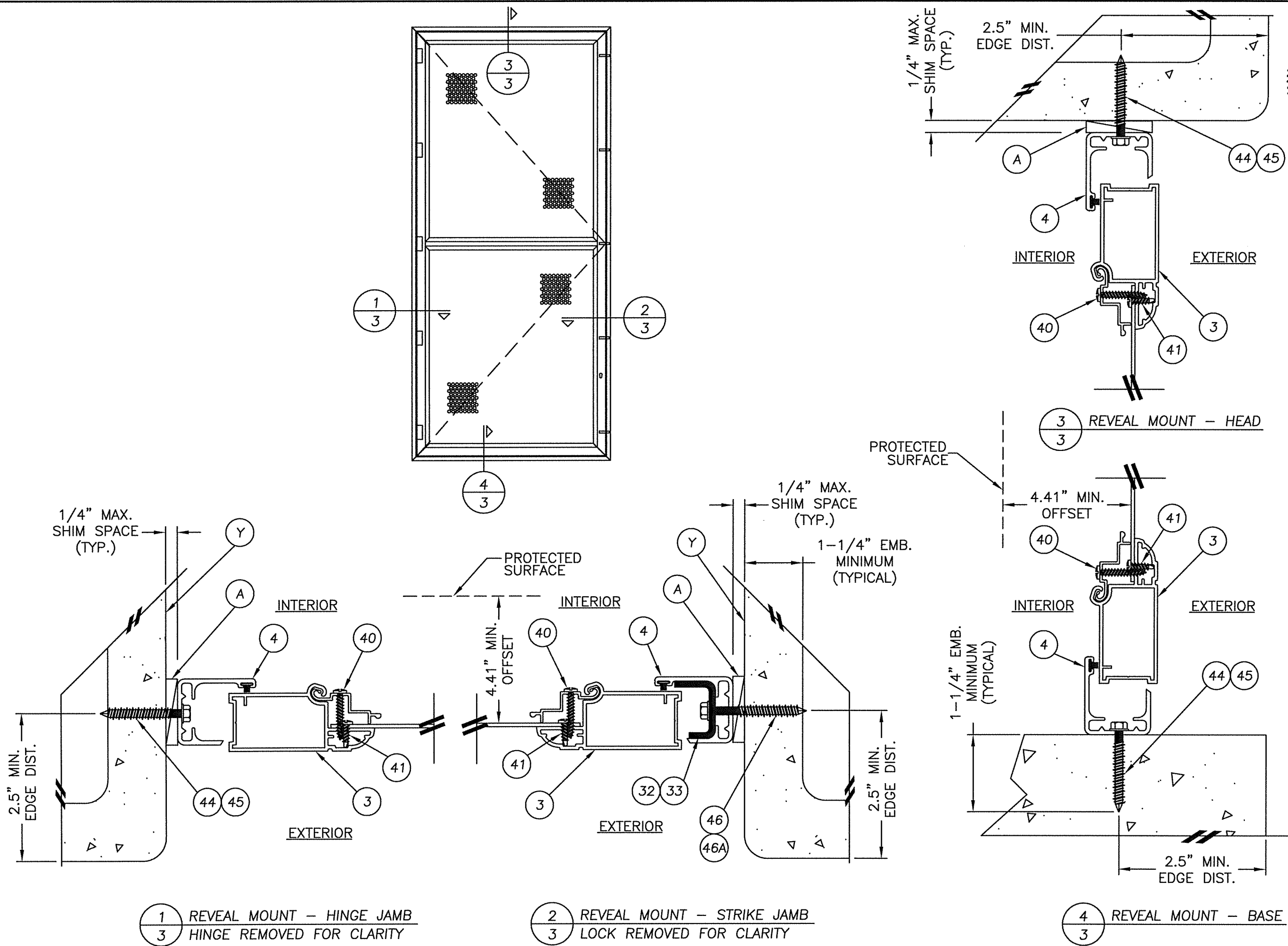

1 REVEAL MOUNT - HINGE JAMB
3 HINGE REMOVED FOR CLARITY

2 REVEAL MOUNT - STRIKE JAMB
3 LOCK REMOVED FOR CLARITY

4 REVEAL MOUNT - BASE
3

Lyndon F. Schmidt
 P.E. No. 43409

R.W.
 BUILDING CONSULTANTS, INC.
 P.O. Box 230, Valrico, FL 33595
 Phone No.: 813.659.9197
 FBPE C.A. No. 9813

PRODUCT:		KANE SCREENS VAN GUARD II	
		ALUMINUM HURRICANE BARRIER	
		PART OR ASSEMBLY:	
		REVEAL MOUNT SECTIONS MASONRY WALLS	
DATE:	8/26/13	NO.	DATE
SCALE:	N.T.S.	BY	
DWG. BY:	JK	REVISIONS	
CHK. BY:	LFS		
DRAWING NO.:	FL-10238.2		
SHEET	3	OF	12

R:\Clients\Kane PERMANENTVA - Florida Product Approvals\FL-10238\C - Drawings\FL 10238 (2017)\FL-10238.1-2.dwg, 4.2

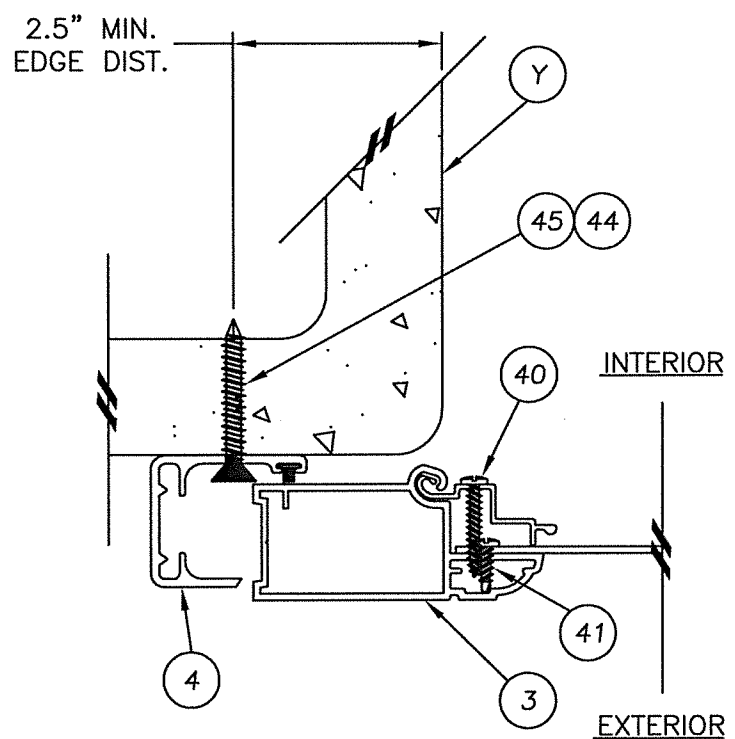

5 ANCHOR THRU SUB-FRAME
4 LOCK ASS'Y REMOVED FOR CLARITY

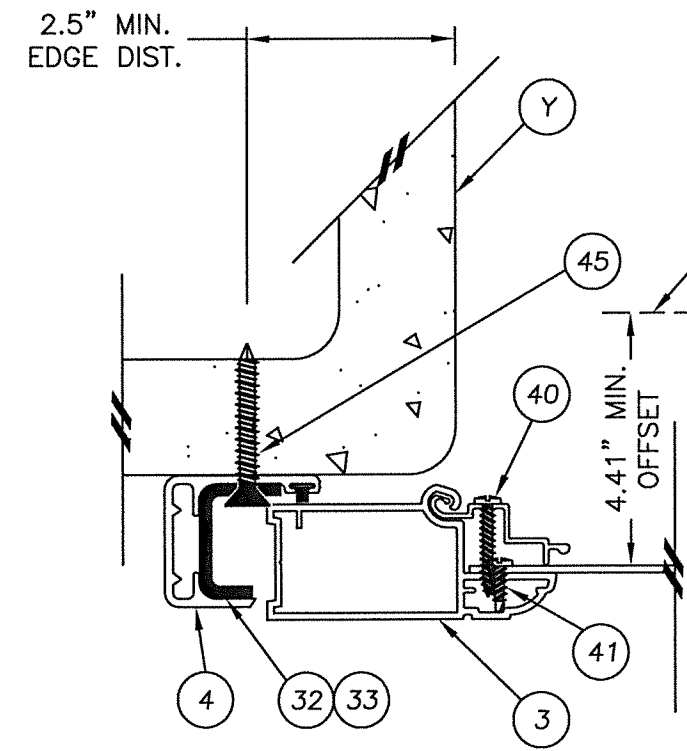
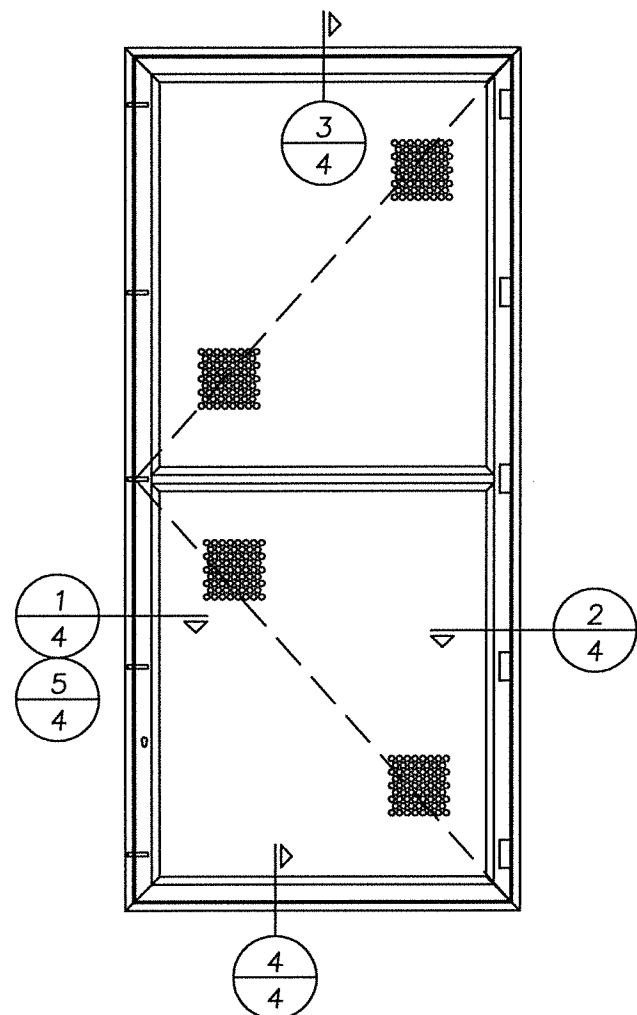

1 ANCHOR THRU J-SHAPE STRIKE PLATE
4 LOCK ASS'Y REMOVED FOR CLARITY

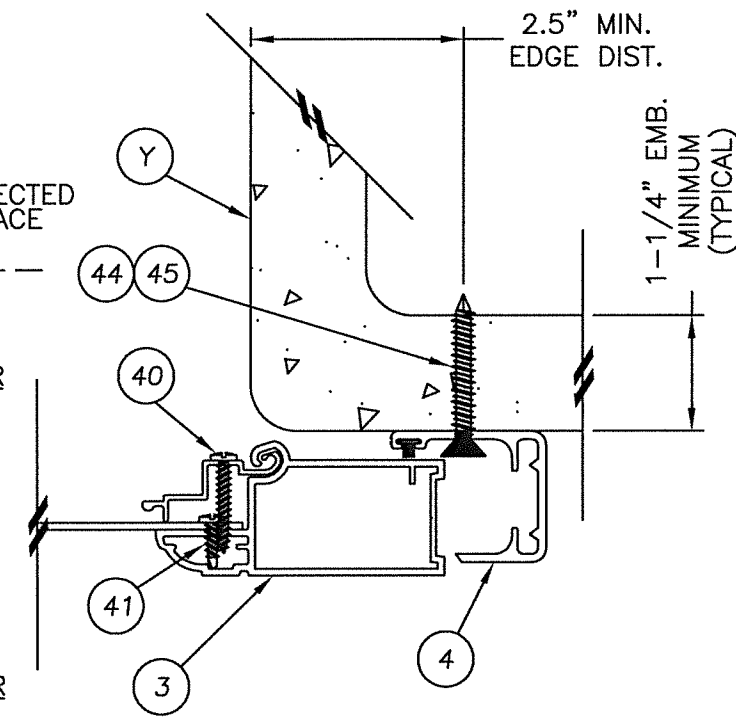

2 SURFACE MOUNT - STRIKE JAMB
4 HINGE REMOVED FOR CLARITY

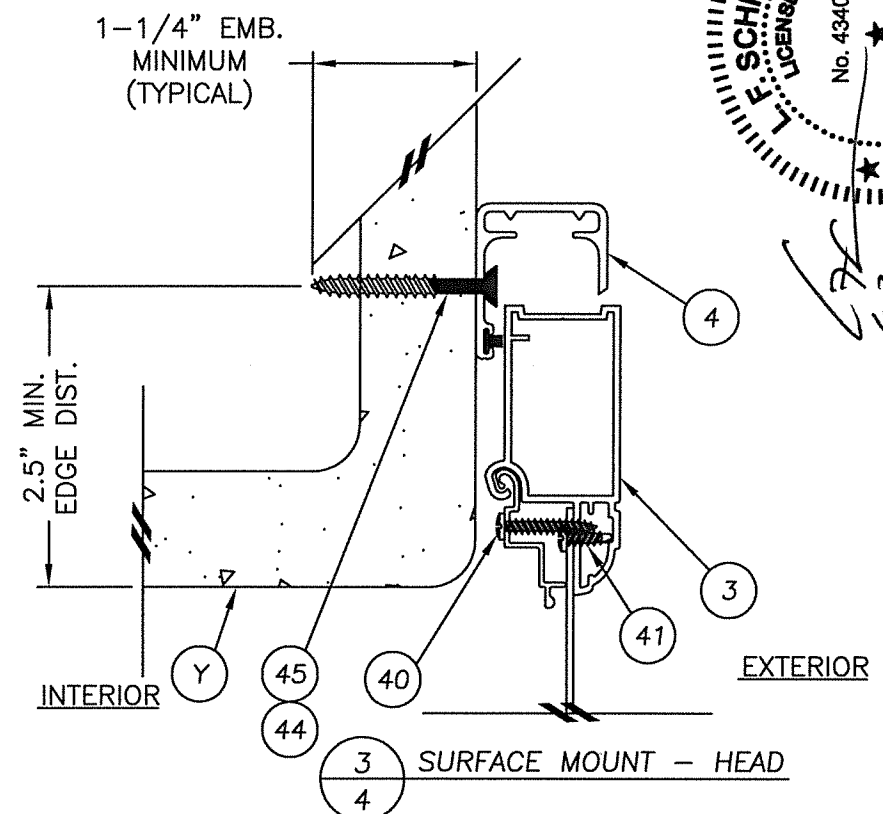

3 SURFACE MOUNT - HEAD
4

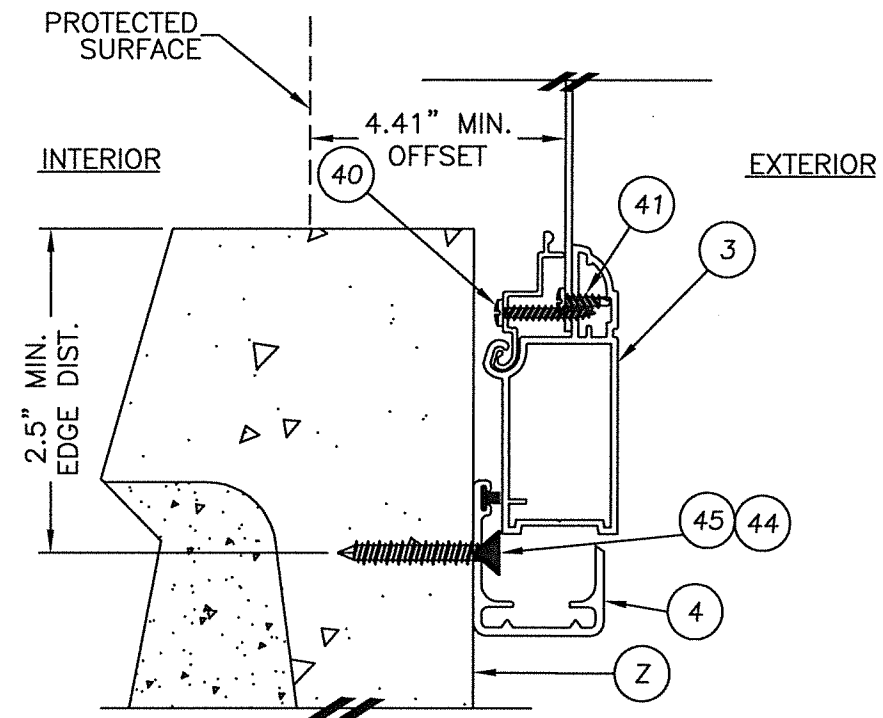

4 SURFACE MOUNT - BASE
4

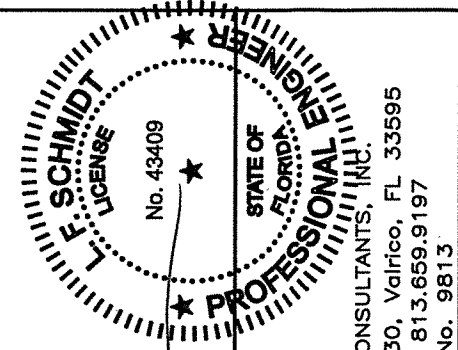

Documents Prepared By:
Lyndon F. Schmidt
P.E. No. 43409

R.W. BUILDING CONSULTANTS, INC.
P.O. Box 230, Valrico, FL 33595
Phone No.: 813.659.9197
FBPE C.A. No. 9813

PRODUCT:
KANE SCREENS
VAN GUARD II
ALUMINUM HURRICANE BARRIER
PART OR ASSEMBLY:
SURFACE MOUNT SECTIONS
MASONRY WALLS

NO.	DATE	BY	REVISIONS
3	9/26/17	JK	UPDATE TO 6TH ED. (2017) FBC
2	7/01/15	LFS	UPDATE TO 5TH ED. (2014) FBC
1	12/10/13	LFS	ADDED POROSITY D.P. RATING

DATE: 8/26/13
SCALE: N.T.S.
DWG. BY: JK
CHK. BY: LFS
DRAWING NO.: FL-10238.2
SHEET 4 OF 12

© 2013 R.W. BUILDING CONSULTANTS INC.

R:\Clients\Kane PERMANENT\A - Florida Product Approvals\FL-10238\C - Drawings\FL-10238 (2017)\FL-10238.1-2.dwg, 5.2

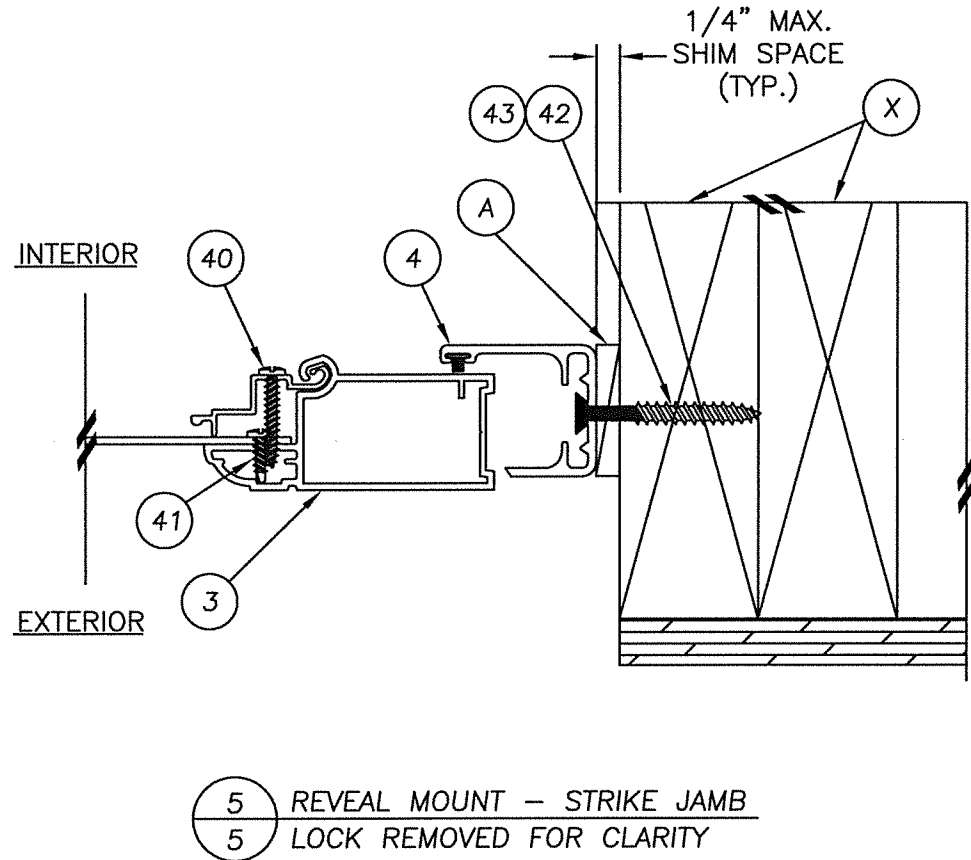
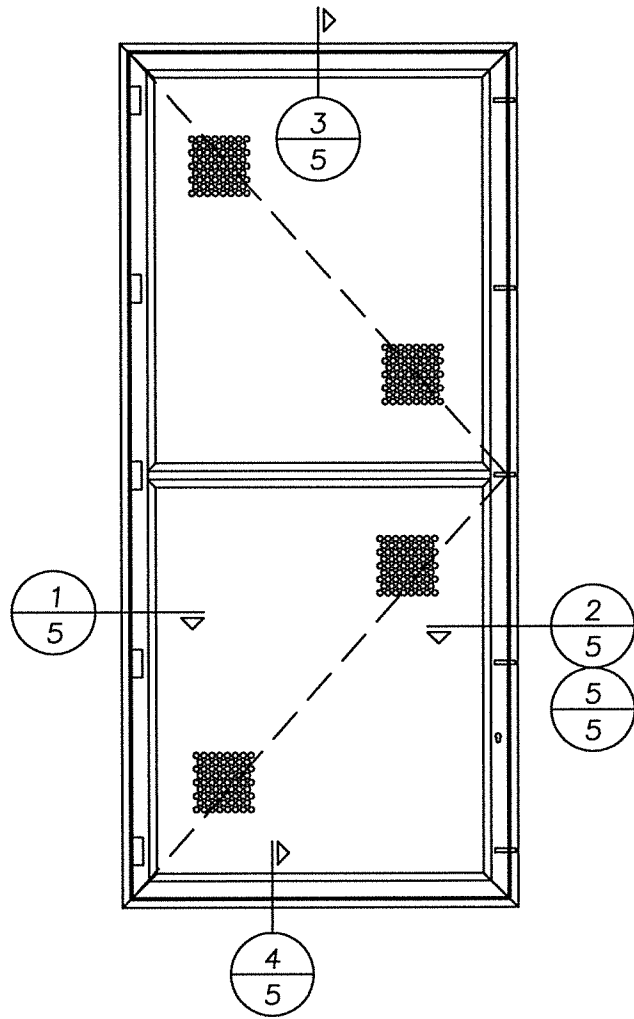

5 REVEAL MOUNT - STRIKE JAMB
5 LOCK REMOVED FOR CLARITY

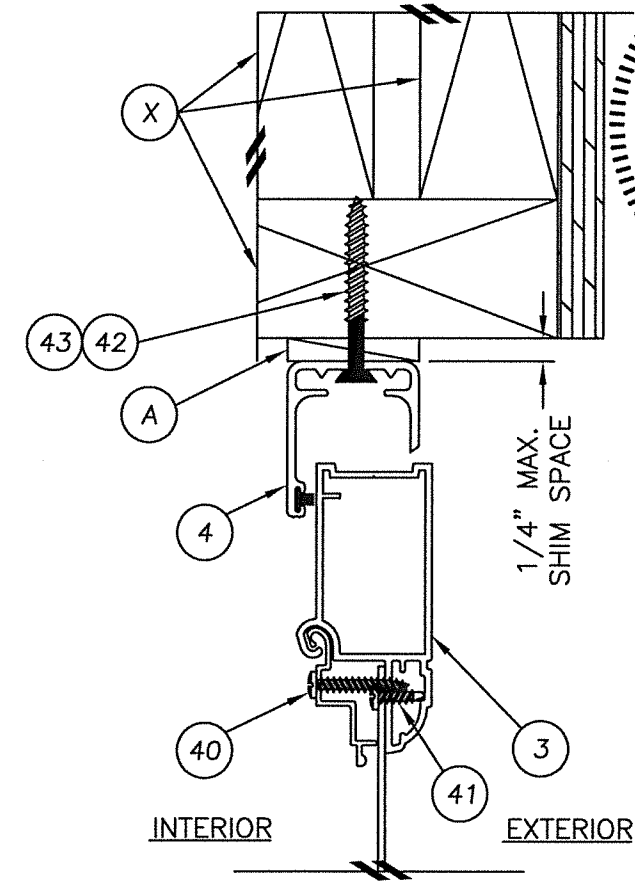

3 REVEAL MOUNT - HEAD
5

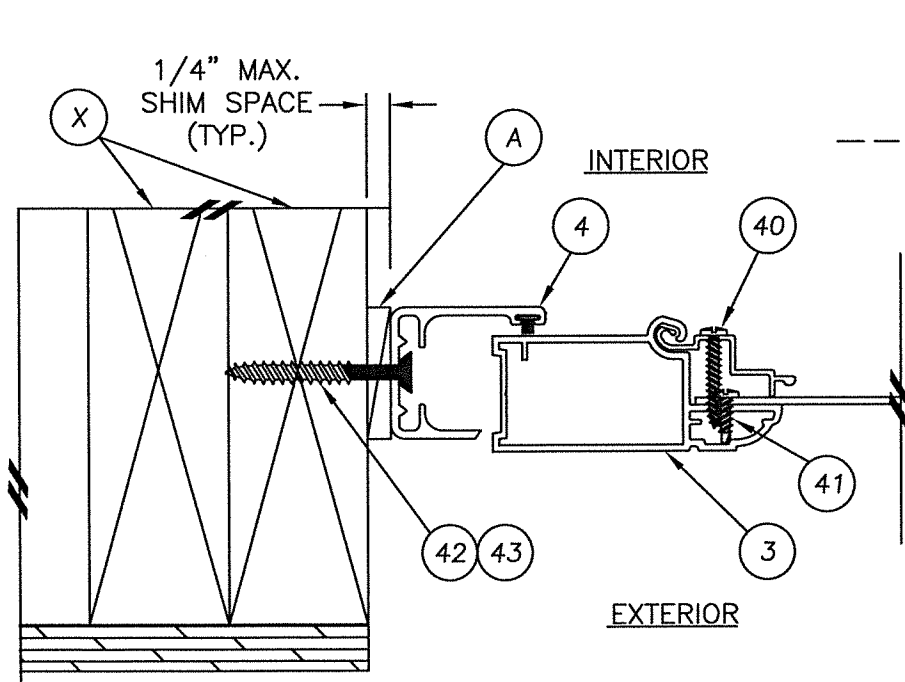

1 REVEAL MOUNT - HINGE JAMB
5 HINGE REMOVED FOR CLARITY

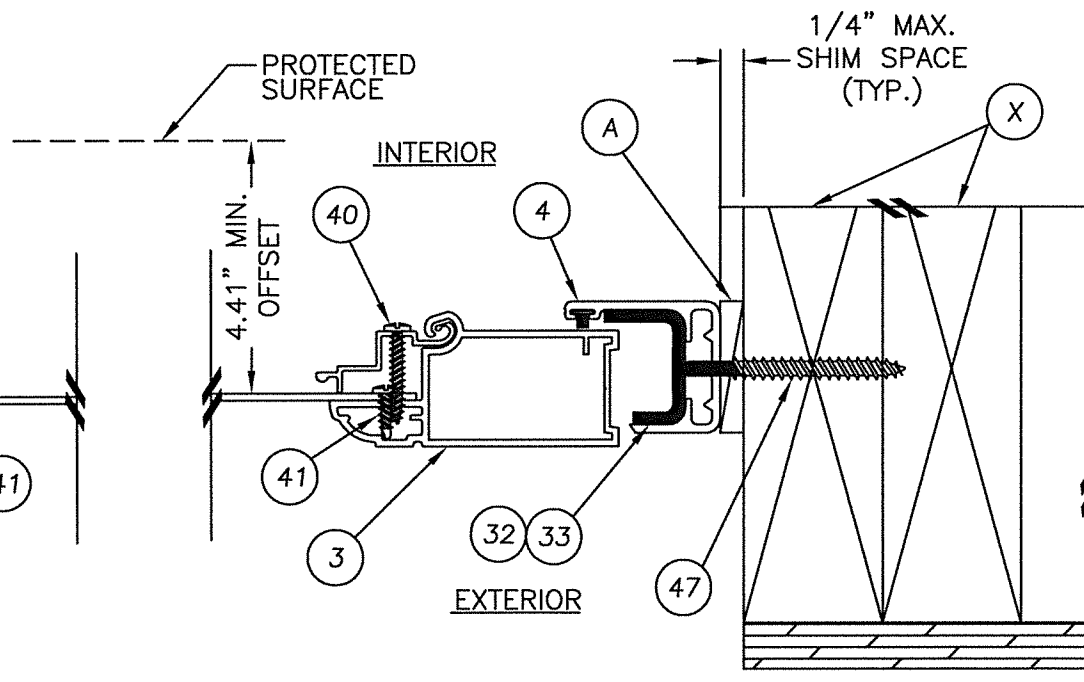

2 REVEAL MOUNT - STRIKE JAMB
5 LOCK REMOVED FOR CLARITY

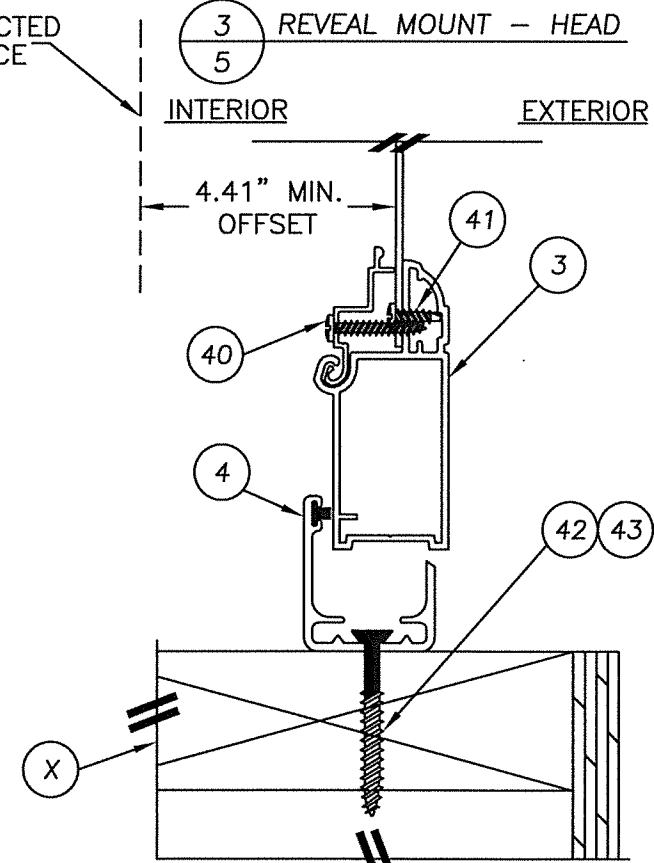

4 REVEAL MOUNT - BASE
5

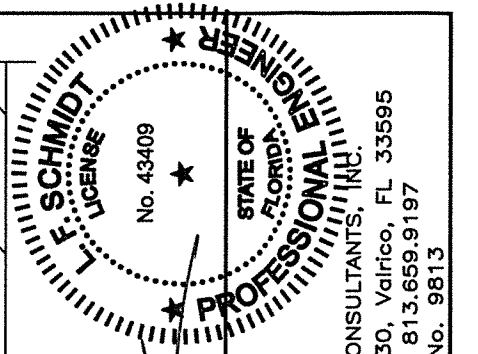

Documents Prepared By:
Lyndon F. Schmidt
P.E. No. 43409

RW BUILDING CONSULTANTS, INC.
P.O. Box 230, Valrico, FL 33595
Phone No.: 813.659.9197
FBPE C.A. No. 9813

PRODUCT: KANE SCREENS VAN GUARD II ALUMINUM HURRICANE BARRIER PART OR ASSEMBLY: REVEAL MOUNT SECTIONS 2X WOOD FRAMING

NO.	DATE	REVISIONS
3	9/26/17	UPDATE TO 6TH ED. (2017) FBC
2	7/01/15	UPDATE TO 5TH ED. (2014) FBC
1	12/10/13	ADDED POROSITY D.P. RATING

DATE: 8/26/13
SCALE: N.T.S.
DWG. BY: JK
CHK. BY: LFS
DRAWING NO.: FL-10238.2
SHEET 5 OF 12

R:\Clients\Kane PERMANENT\A - Florida Product Approvals\FL-10238\C - Drawings\FL-10238 (2017)\FL-10238.1-2.dwg, 6.2

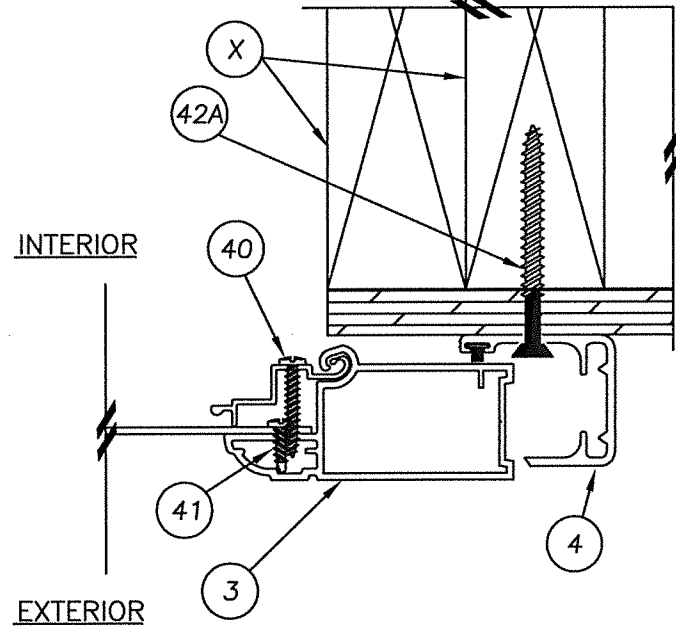
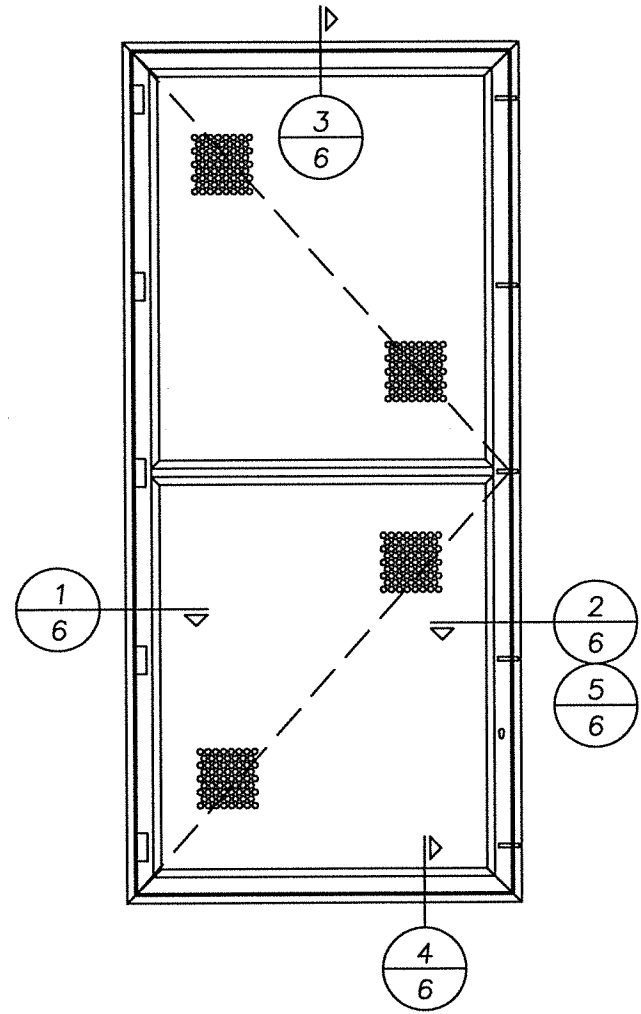

5 ANCHOR THRU SUB-FRAME
6 LOCK REMOVED FOR CLARITY

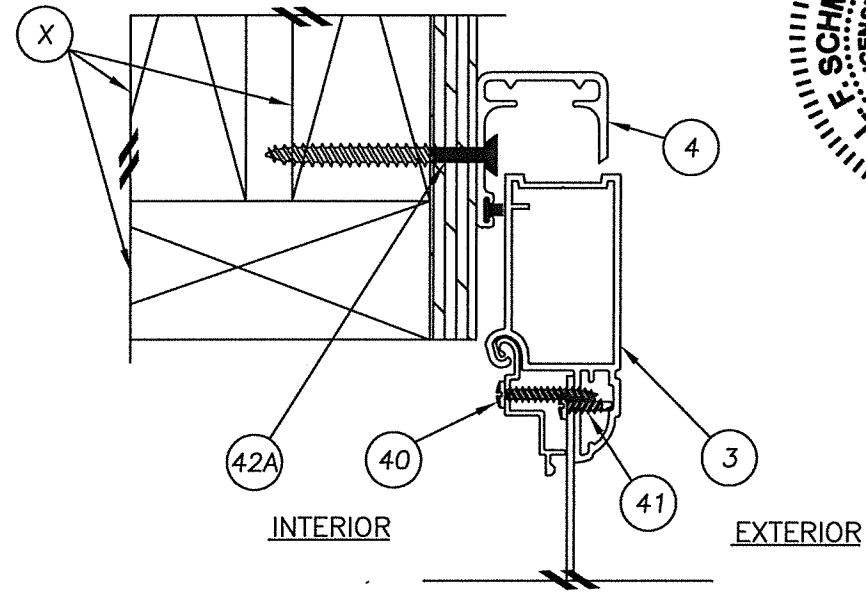

3 SURFACE MOUNT - HEAD
6 LOCK REMOVED FOR CLARITY

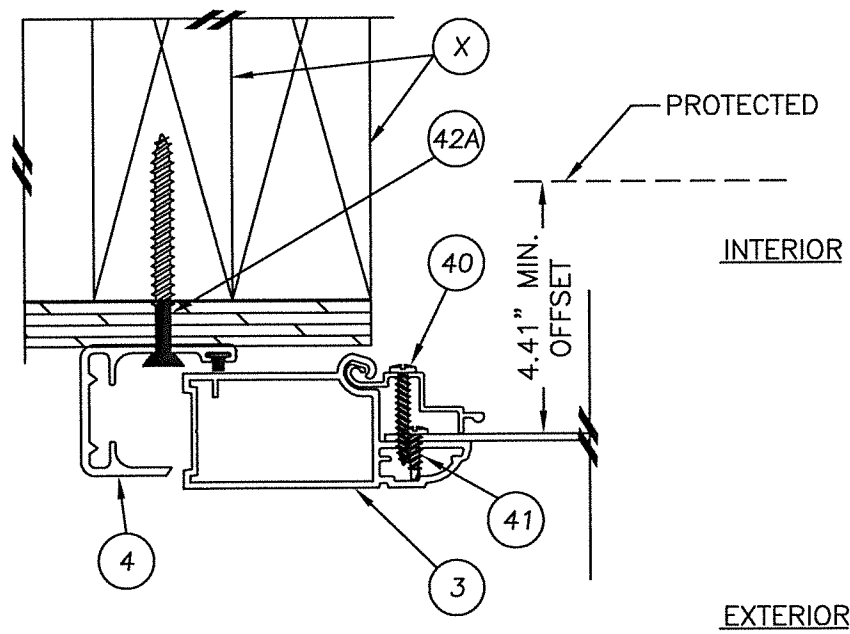

1 SURFACE MOUNT - HINGE JAMB
6 HINGE REMOVED FOR CLARITY

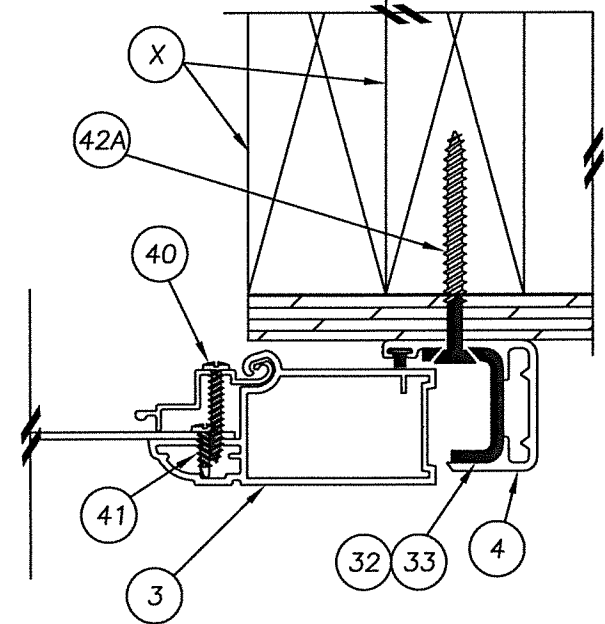

2 ANCHOR THRU J-SHAPE STRIKE PLATE
6 LOCK REMOVED FOR CLARITY

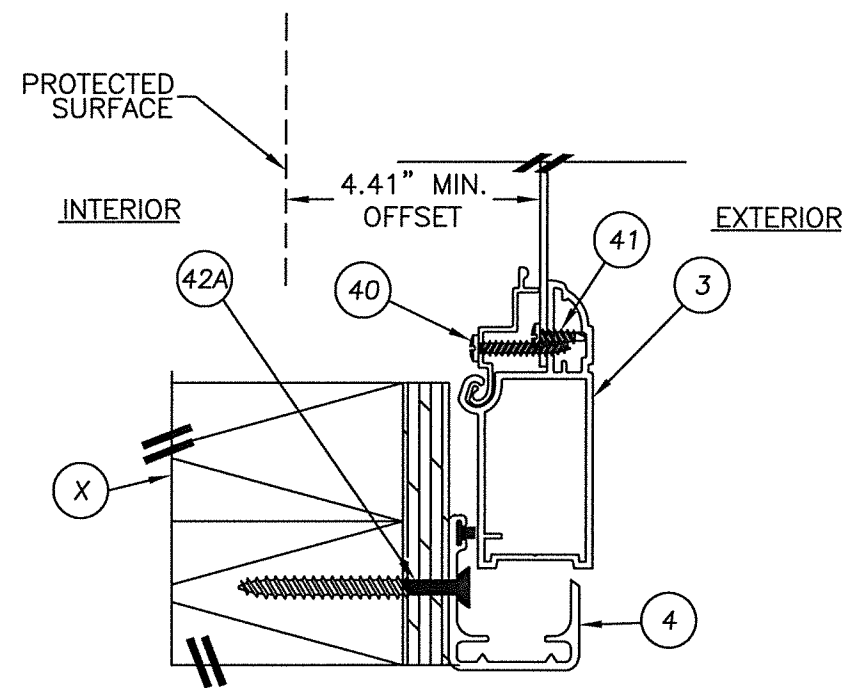

4 SURFACE MOUNT - BASE
6 LOCK REMOVED FOR CLARITY

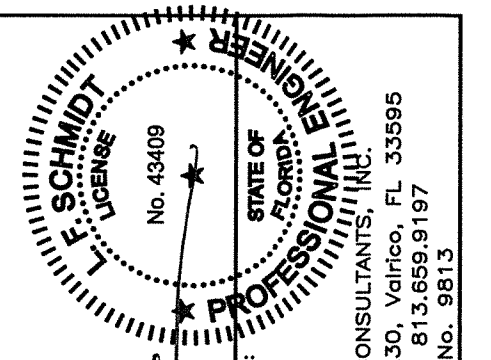

Documents Prepared By:
Lyndon F. Schmidt
P.E. No. 43409
10.3.17

R.W. BUILDING CONSULTANTS, INC.
P.O. Box 230, Valrico, FL 33595
Phone No.: 813.659.9197
FBPE C.A. No. 9813

PRODUCT:
KANE SCREENS
VAN GUARD II
ALUMINUM HURRICANE BARRIER
PART OR ASSEMBLY:
SURFACE MOUNT SECTIONS
2X WOOD FRAMING

NO.	DATE	REVISIONS
3	9/26/17	UPDATE TO 6TH ED. (2017) FBC
2	7/01/15	UPDATE TO 5TH ED. (2014) FBC
1	12/10/13	ADDED POROSITY D.P. RATING
		NO. DATE
		BY
		LFS
		JK

DATE: 8/26/13
SCALE: N.T.S.
DWG. BY: JK
CHK. BY: LFS
DRAWING NO.: FL-10238.2
SHEET 6 OF 12

© 2013 R.W. BUILDING CONSULTANTS INC.

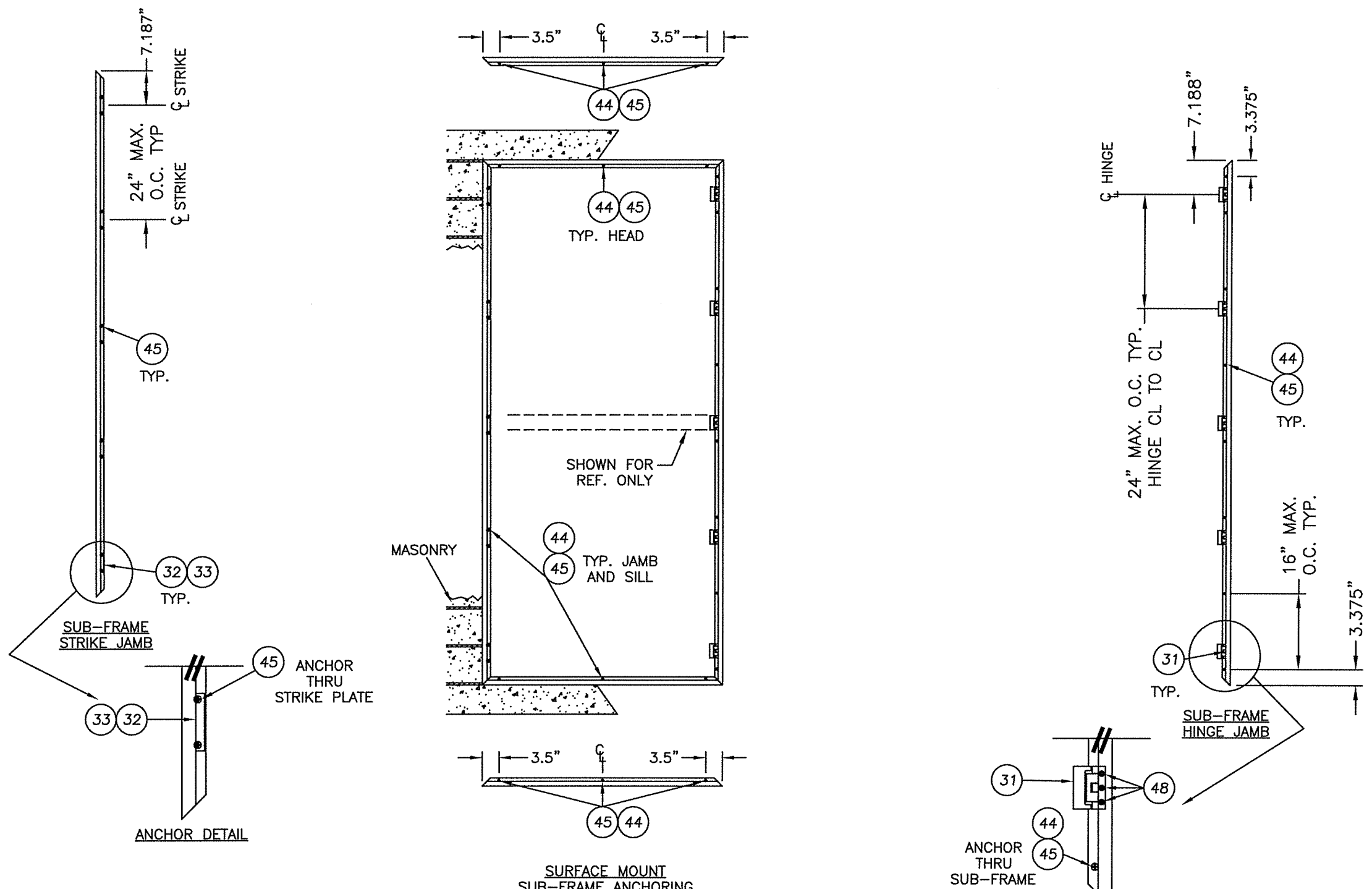

CONCRETE ANCHOR NOTES:

1. Substitution of equal concrete anchors from a different supplier may have different edge distance and center distance requirements.
2. Concrete anchor locations at the corners may be adjusted to maintain the min. edge distance to mortar joints. Concrete anchor locations noted as "MAX. ON CENTER" must be adjusted to maintain the min. edge distance to mortar joints, additional concrete anchors may be required to ensure the "MAX. ON CENTER" dimension are not exceeded.
3. Concrete anchor table:

ANCHOR TYPE	ANCHOR SIZE	MIN. EMBEDMENT	MIN. CLEARANCE TO MASONRY EDGE	MIN. CLEARANCE TO ADJACENT ANCHOR
ITW TAPCON®	1/4"	1-1/4"	2-1/2"	4" (3-1/8" @ STRIKE)

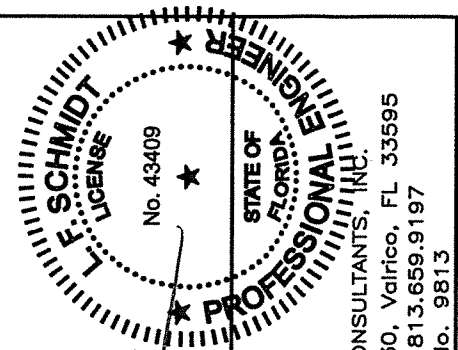

Documents Prepared By:
Lyndon F. Schmidt
P.E. No. 43409

R.W. BUILDING CONSULTANTS, INC.
P.O. Box 230, Valrico, FL 33595
Phone No.: 813.659.9197
FBPE C.A. No. 9813

PRODUCT: KANE SCREENS VAN GUARD II ALUMINUM HURRICANE BARRIER
PART OR ASSEMBLY: SURFACE MOUNT ANCHORING MASONRY WALL

NO.	DATE	REVISIONS	BY
3	9/26/17	UPDATE TO 6TH ED. (2017) FBC	JK
2	7/01/15	UPDATE TO 5th ED. (2014) FBC	LFS
1	12/10/13	ADDED POROSITY D.P. RATING	LFS

DATE: 8/26/13
SCALE: N.T.S.
DWG. BY: JK
CHK. BY: LFS
DRAWING NO.: FL-10238.2
SHEET 7 OF 12

R:\Clients\Kane PERMANENT\TA - Florida Product Approvals\FL-10238\C - Drawings\FL 10238 (2017)\FL-10238.1-2.dwg, 8.2

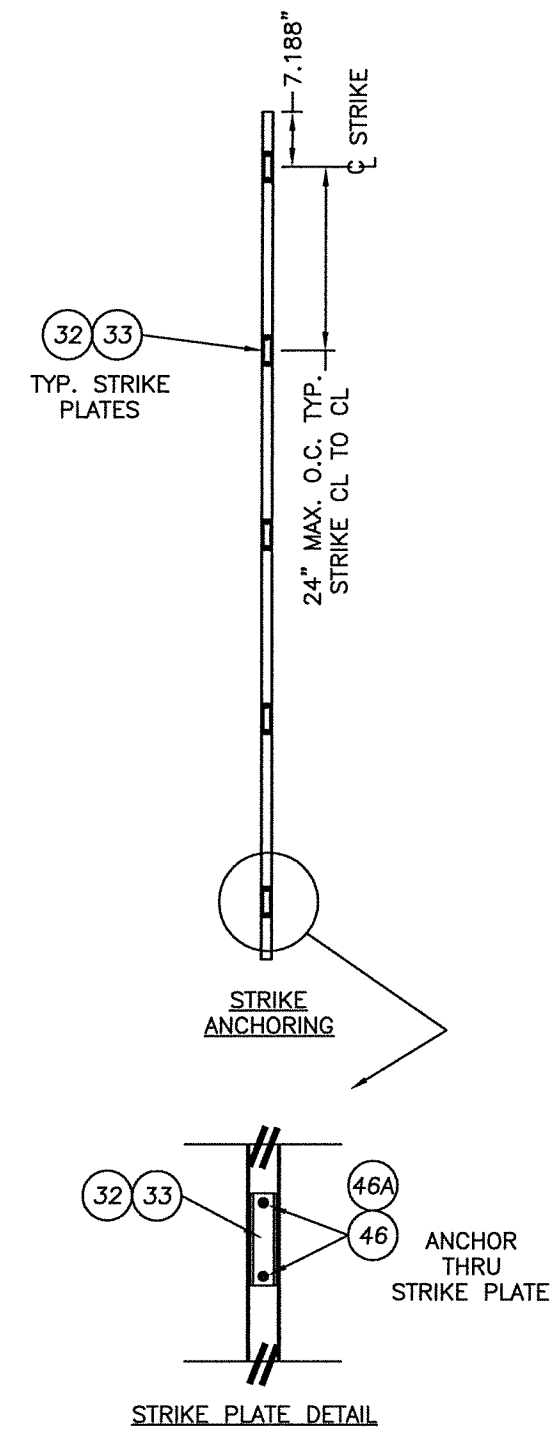
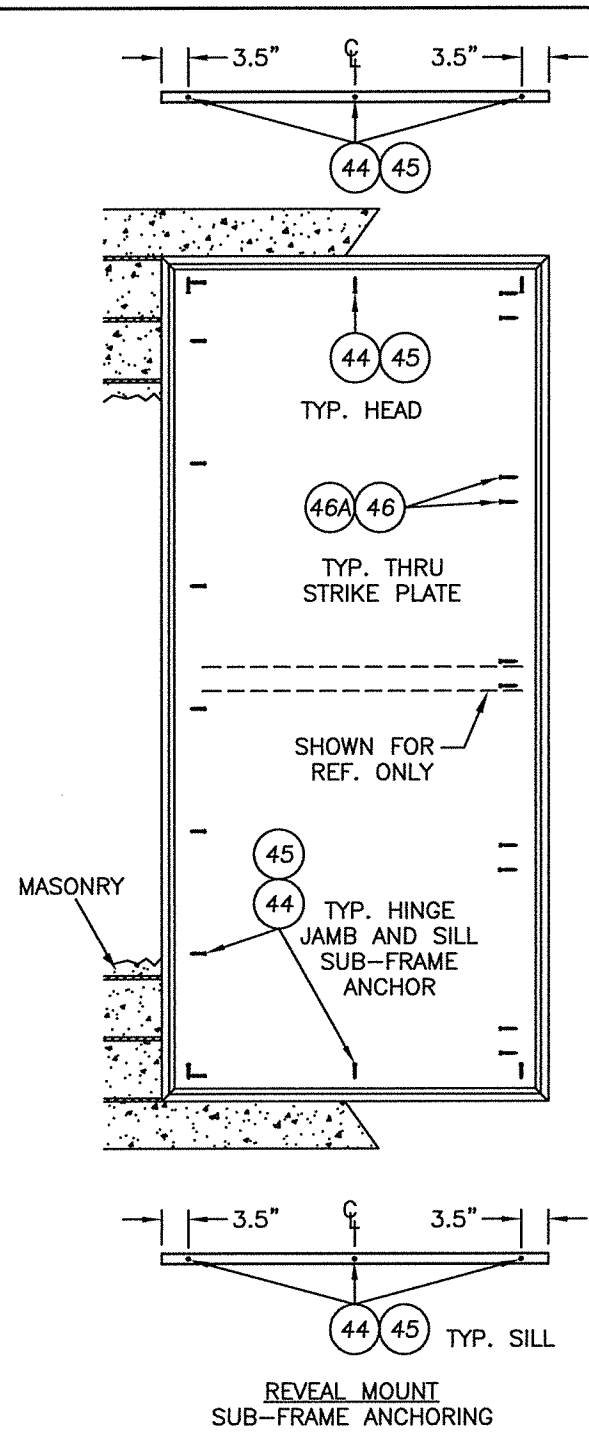
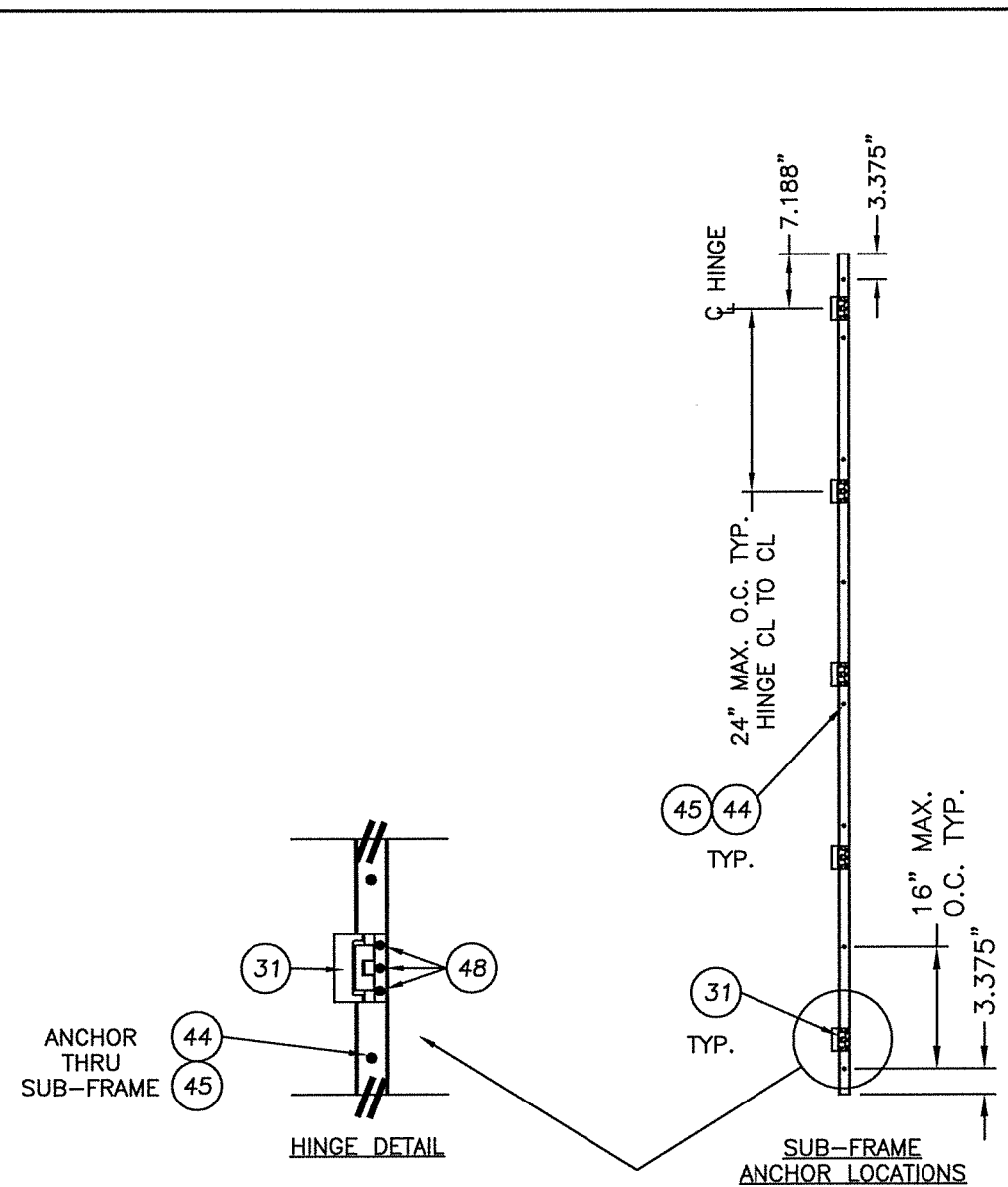

CONCRETE ANCHOR NOTES:

1. Substitution of equal concrete anchors from a different supplier may have different edge distance and center distance requirements.
2. Concrete anchor locations at the corners may be adjusted to maintain the min. edge distance to mortar joints. Concrete anchor locations noted as "MAX. ON CENTER" must be adjusted to maintain the min. edge distance to mortar joints, additional concrete anchors may be required to ensure the "MAX. ON CENTER" dimension are not exceeded.
3. Concrete anchor table:

ANCHOR TYPE	ANCHOR SIZE	MIN. EMBEDMENT	MIN. CLEARANCE TO MASONRY EDGE	MIN. CLEARANCE TO ADJACENT ANCHOR
ITW TAPCON®	1/4"	1-1/4"	2-1/2"	4" (3-1/8" @ STRIKE)

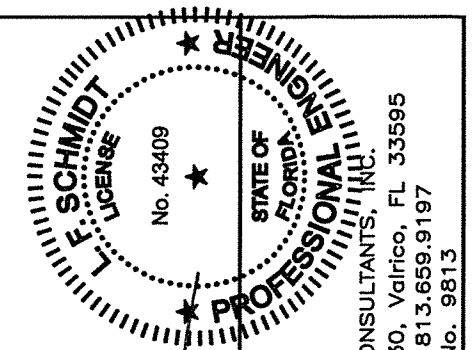

Documents Prepared By:
Lyndon F. Schmidt
P.E. No. 43409

RW BUILDING CONSULTANTS, INC.
P.O. Box 230, Valrico, FL 33595
Phone No.: 813.659.9197
FBPE C.A. No. 9813

PRODUCT:
KANE SCREENS
VAN GUARD II
ALUMINUM HURRICANE BARRIER
PART OR ASSEMBLY:
REVEAL MOUNT ANCHORING
MASONRY WALL

NO.	DATE	BY	REVISIONS
3	9/26/17	JK	UPDATE TO 6TH ED. (2017) FBC
2	7/01/15	LFS	UPDATE TO 5TH ED. (2014) FBC
1	12/10/13	LFS	ADDED POROSITY D.P. RATING

DATE: 8/26/13
SCALE: N.T.S.
DWG. BY: JK
CHK. BY: LFS
DRAWING NO.: FL-10238.2
SHEET 8 OF 12

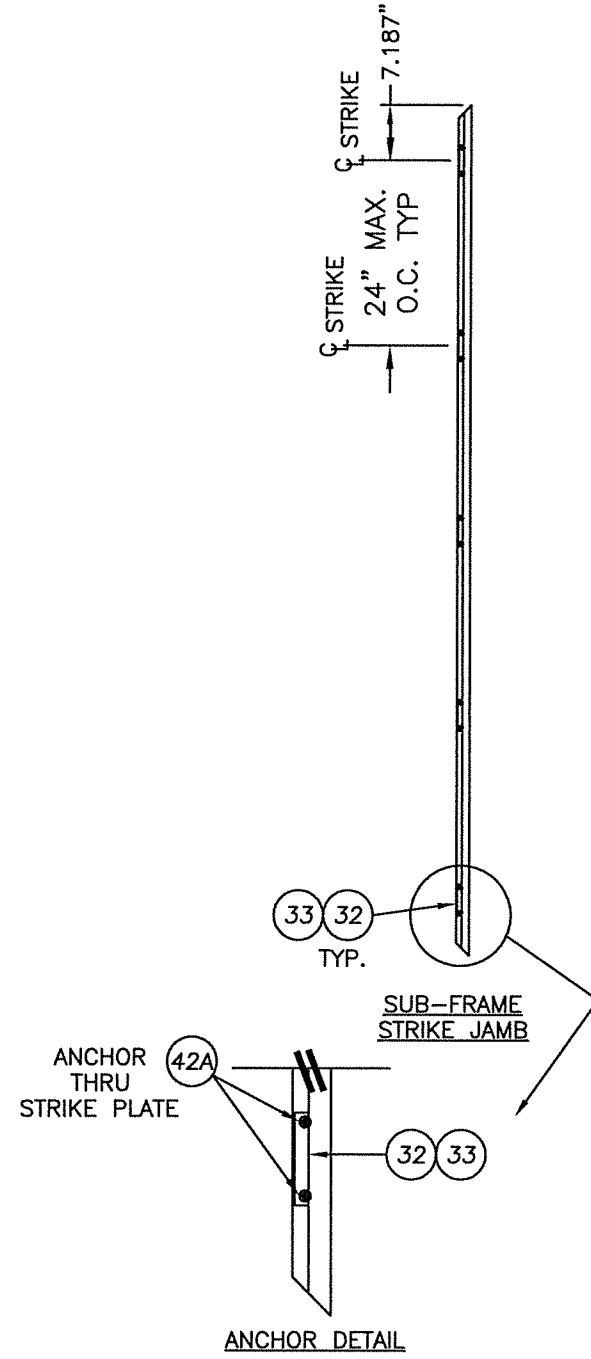
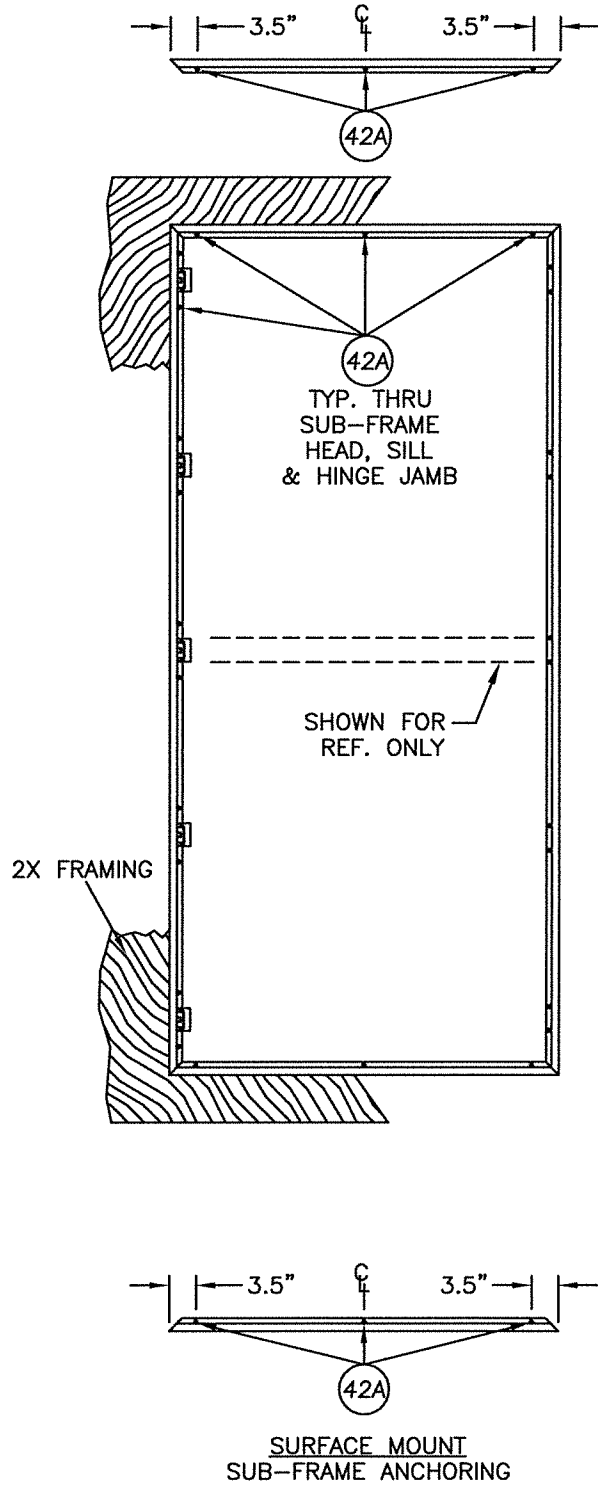
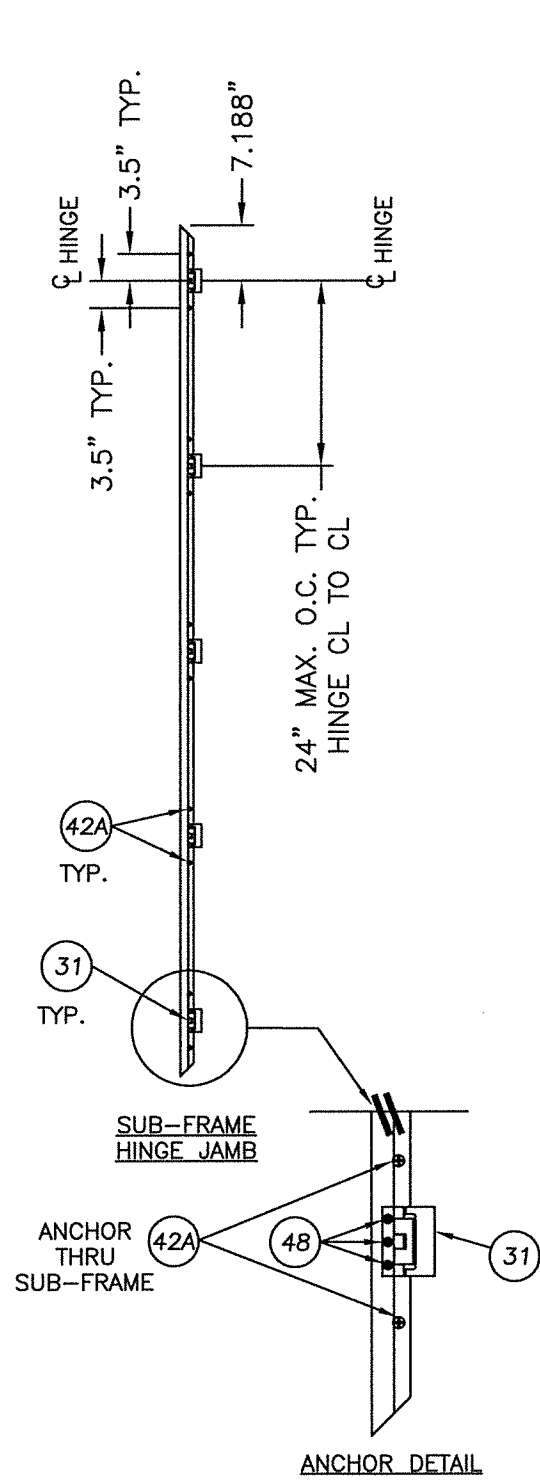

DATE: 8/26/13
 SCALE: N.T.S.
 DWG. BY: JK
 CHK. BY: LFS
 DRAWING NO.: FL-10238.2
 SHEET 9 OF 12

NO.	DATE	REVISIONS
3	9/26/17	UPDATE TO 6TH ED. (2017) FBC
2	7/01/15	UPDATE TO 5TH ED. (2014) FBC
1	12/10/13	ADDED POROSITY D.P. RATING

PRODUCT: KANE SCREENS VAN GUARD II ALUMINUM HURRICANE BARRIER PART OR ASSEMBLY: SURFACE MOUNT ANCHORING 2X WOOD FRAMING

Documents Prepared By: Lyndon F. Schmidt P.E. No. 43409

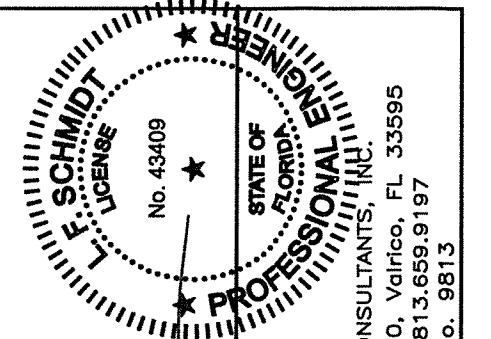

R.W. BUILDING CONSULTANTS, INC.
 P.O. Box 230, Valrico, FL 33595
 Phone No.: 813.659.9197
 FBPE C.A. No. 9813

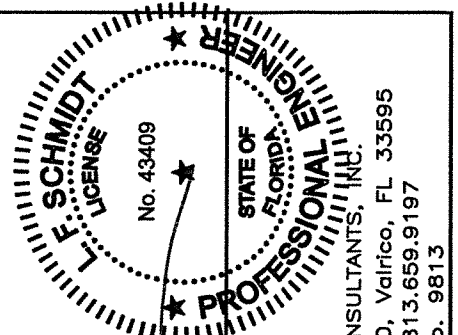
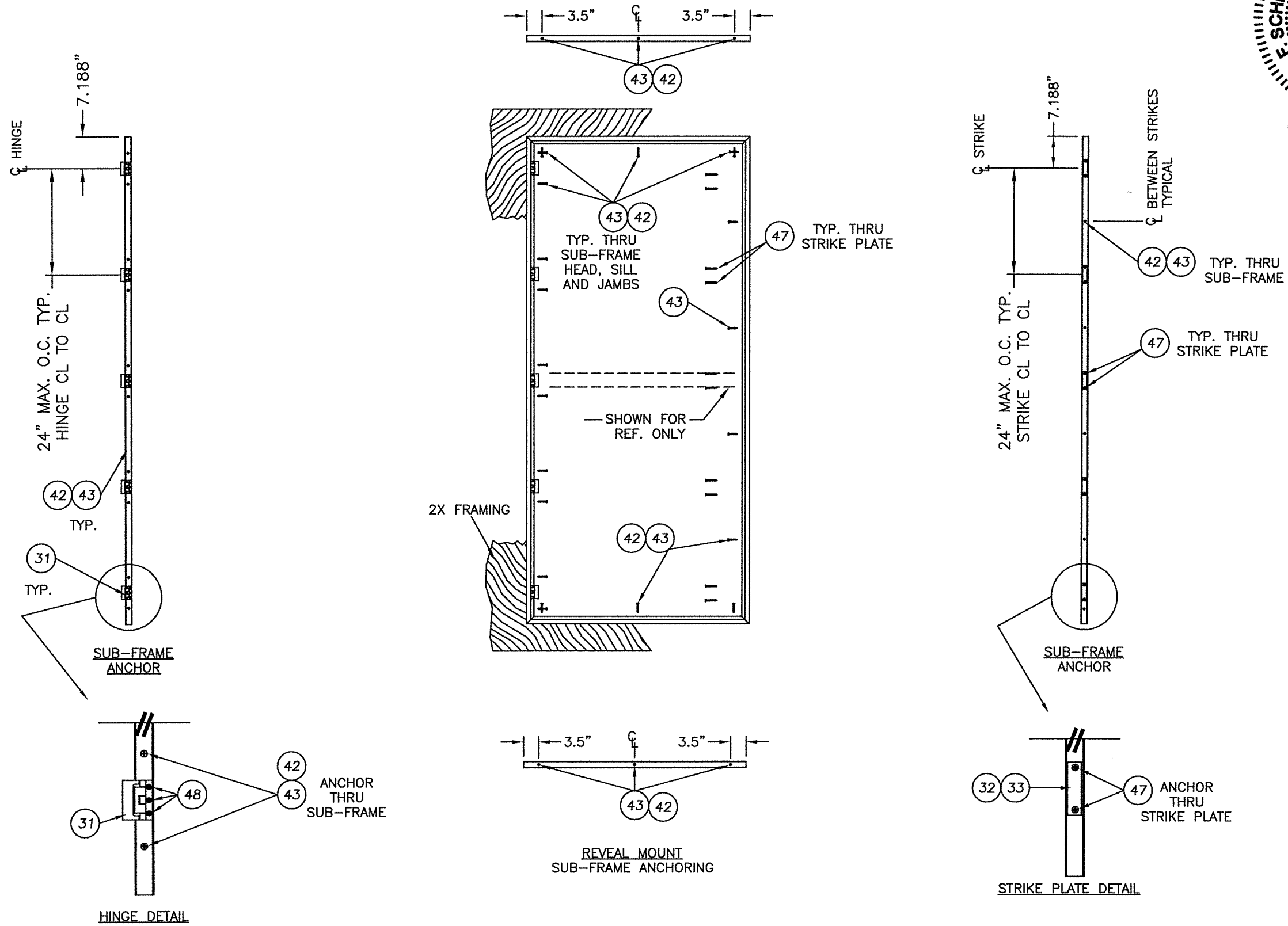

Documents Prepared By:
 Lyndon F. Schmidt
 P.E. No. 43409
 10-3-17
 R.W. BUILDING CONSULTANTS, INC.
 P.O. Box 230, Valrico, FL 33595
 Phone No.: 813.659.9197
 FBPE C.A. No. 9813

PRODUCT:
 KANE SCREENS
 VAN GUARD II
 ALUMINUM HURRICANE BARRIER
 PART OR ASSEMBLY:
 REVEAL MOUNT ANCHORING
 2X WOOD FRAMING

NO.	DATE	REVISIONS
3	9/26/17	UPDATE TO 6TH ED. (2017) FBC
2	7/01/15	UPDATE TO 5th ED. (2014) FBC
1	12/10/13	ADDED POROSITY D.P. RATING
NO.	DATE	

DATE: 8/26/13
 SCALE: N.T.S.
 DWG. BY: JK
 CHK. BY: LFS
 DRAWING NO.: FL-10238.2
 SHEET 10 OF 12

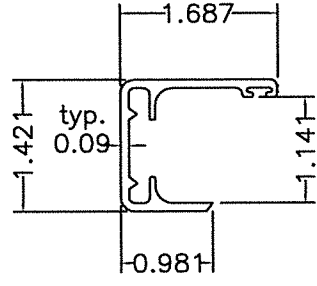

4 SUB FRAME

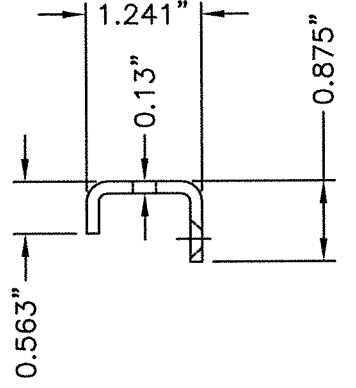

32 J STRIKE PLATE

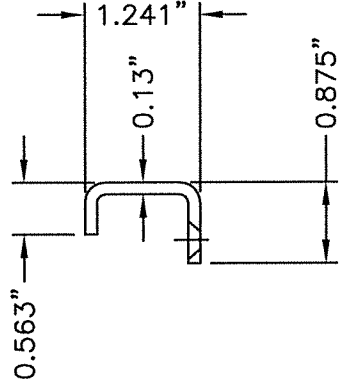
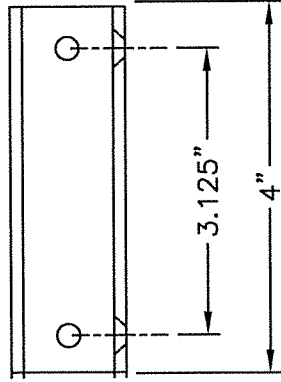

33 EXTENDED J STRIKE PLATE

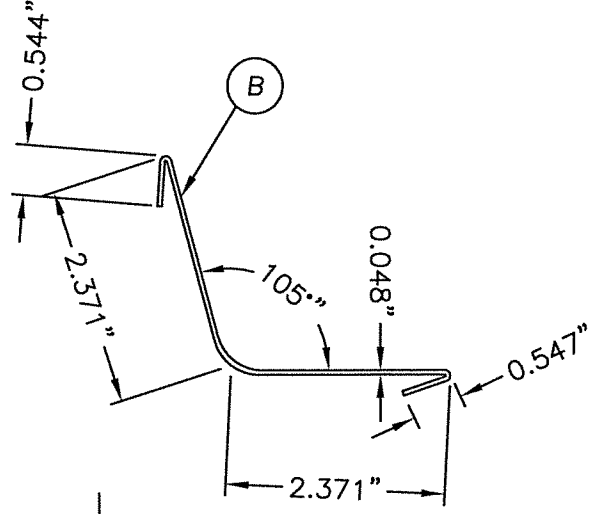
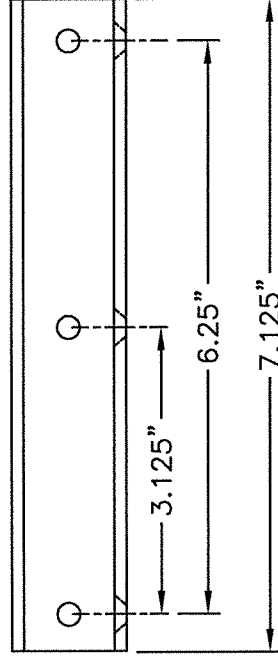

B MAIN FRAME CORNER SIDE VIEW

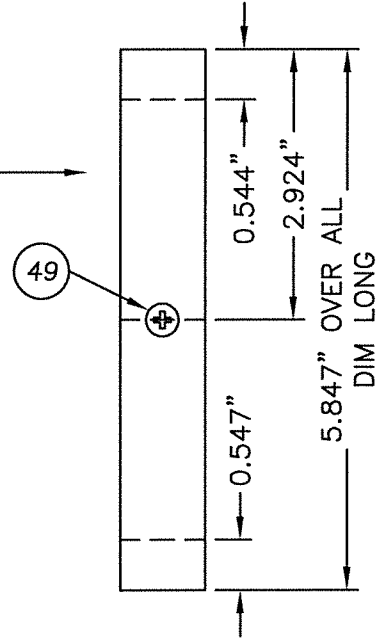

B MAIN FRAME CORNER ANGLE WRAP

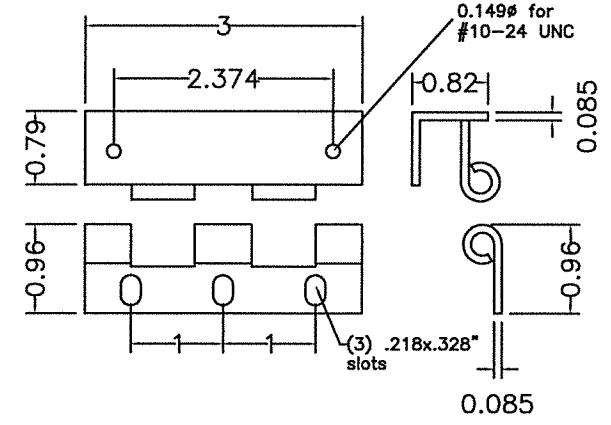

31 TYPICAL HINGE

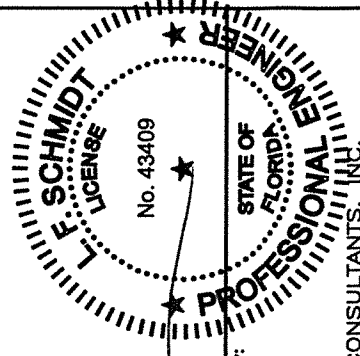

6-2-17
 Documents Prepared By:
 Lyndon F. Schmidt
 P.E. No. 43409

R.W.
 BUILDING CONSULTANTS, INC.
 P.O. Box 230, Valrico, FL 33595
 Phone No.: 813.659.9197
 FBPE C.A. No. 9813

PRODUCT:
 KANE SCREENS
 VAN GUARD II
 ALUMINUM HURRICANE BARRIER
 PART OR ASSEMBLY:
 COMPONENTS
 AND HARDWARE DETAILS

NO.	DATE	DESCRIPTION	BY
3	9/26/17	UPDATE TO 6TH ED. (2017) FBC	JK
2	7/01/15	UPDATE TO 5TH ED. (2014) FBC	LFS
1	12/10/13	ADDED POROSITY D.P. RATING	LFS
		REVISIONS	

DATE: 8/26/13
 SCALE: N.T.S.
 DWG. BY: JK
 CHK. BY: LFS
 DRAWING NO.: FL-10238.2
 SHEET 11 OF 12

R:\Clients\Kane PERMANENT\A - Florida Product Approvals\FL-10238\C - Drawings\FL-10238-1-2.dwg, 12.2

BILL OF MATERIALS (ANCHOR)		MATERIAL
S1	SCREEN DETAIL (STAINLESS STEEL)	STEEL
X	2X FRAMING (SG >= 0.55)	WOOD
Y	HOLLOW BLOCK CMU (ASTM C90)	CONCRETE
Z	CONCRETE MASONRY (3000 PSI MIN. - ACI 301)	CONCRETE
A	1/4" MAX. SHIM	WOOD
B	MAIN FRAME CORNER ANGLE WRAP	STEEL
3	MAIN FRAME 6063-T6	ALUMINUM
4	SUB FRAME 6063-T6	ALUMINUM
5	HORIZONTAL BRACE 6063-T6	ALUMINUM
6	MAINFRAME COVER 6063-T6	ALUMINUM
7	MAIN FRAME CORNER KEY 6063-T6	ALUMINUM
8	MAIN FRAME SECONDARY CORNER KEY 6063-T6	ALUMINUM
9	HORIZONTAL BRACE CORNER KEY 6063-T6	ALUMINUM
30	LOCK ASSEMBLY	STEEL
31	HINGE ASSEMBLY (TYPE 304 STAINLESS STEEL)	ST. STEEL
32	J STRIKE PLATE (TYPE 304 STAINLESS STEEL)	ST. STEEL
33	EXTENDED J STRIKE PLATE (TYPE 304 STAINLESS STEEL)	ST. STEEL
40	#8 X 1" SQ DRIVE PAN HEAD SMS	ST. STEEL
41	#8 X 1/2 SELF-TAP SQ HEAD SMS	ST. STEEL
42	#14 X 2" PFH WOOD SCREW (1-1/2" MIN. EMBEDMENT)	STEEL
42A	#14 X 2-1/2" PFH WOOD SCREW (1-3/4" MIN. EMBEDMENT)	STEEL
43	#14 X 2" PAN HEAD SMS (1-1/2" MIN. EMBEDMENT)	STEEL
44	1/4" X 1-3/4" HWH ITW TAPCON CONCRETE SCREW	STEEL
45	1/4" X 1-3/4" PFH ITW TAPCON CONCRETE SCREW	STEEL
46	1/4" X 2-1/4" HWH ITW TAPCON CONCRETE SCREW	STEEL
46A	1/4" X 2-1/4" PFH ITW TAPCON CONCRETE SCREW	STEEL
47	#14 X 2-1/2" PFH SCREW (1-5/8" MIN. EMBEDMENT)	STEEL
48	#10 X 3/8" SELF-TAP HWH-SLOTTED SCREW	STEEL
50	#10 X 1-1/4" SELF DRILLING TAPPING SCREW	ST. STEEL
51	#10 X 3/8" THREAD CUTTING SCREW	ST. STEEL

WOOD SCREW INSTALLATION NOTES:

- Maintain a minimum 3/4" edge distance, 1" end distance, & 1" o.c. spacing of wood screws to prevent the splitting of wood.

LOCK RELEASE OPTIONS

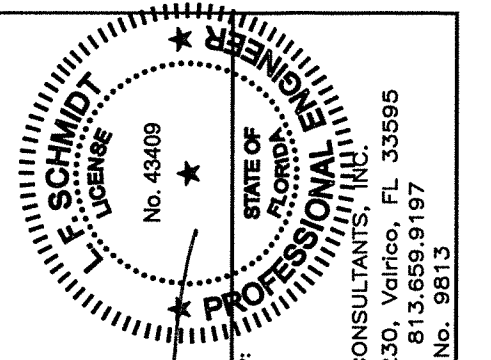
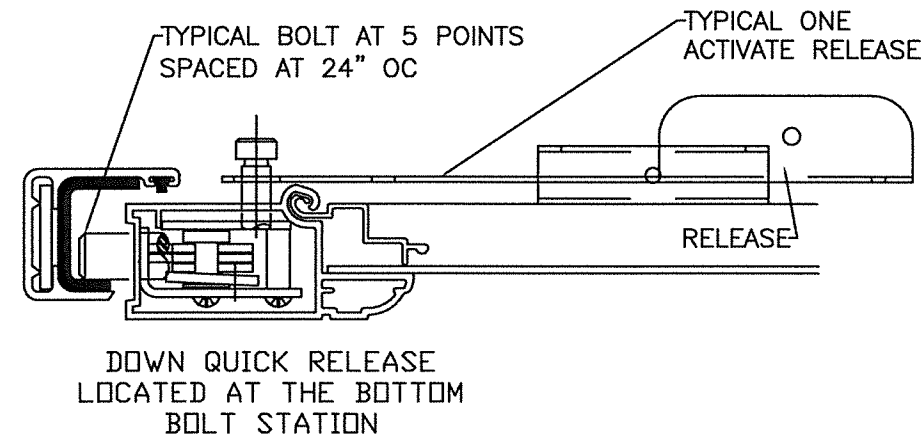
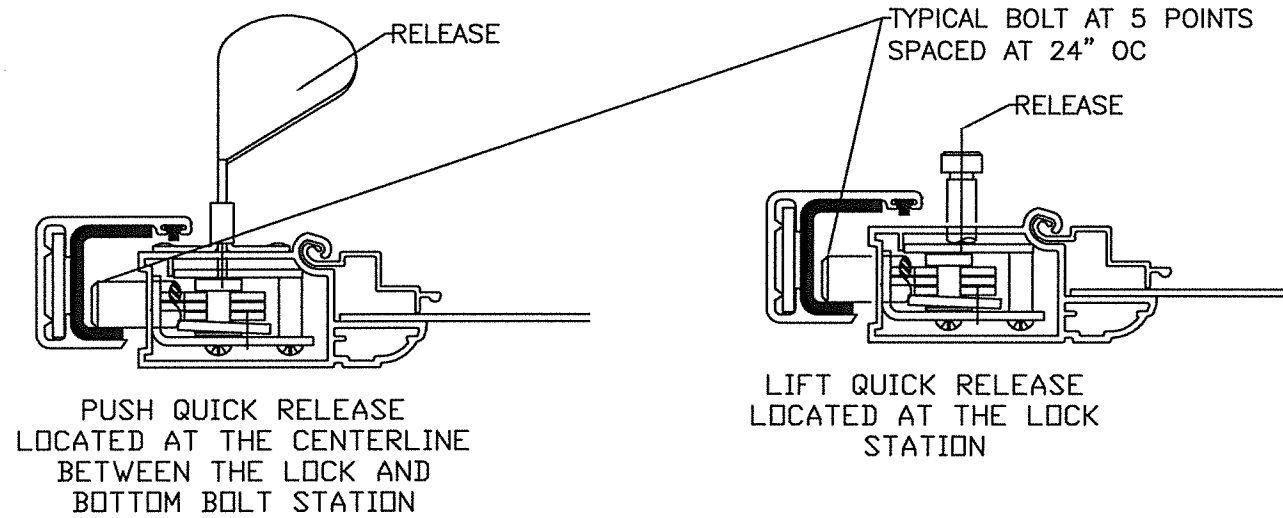

Documents Prepared By:
Lyndon F. Schmidt
P.E. No. 43409

RW BUILDING CONSULTANTS, INC.
P.O. Box 230, Vairico, FL 33595
Phone No.: 813.659.9197
FBPE C.A. No. 9813

PRODUCT:
KANE SCREENS
VAN GUARD II
ALUMINUM HURRICANE BARRIER

PART OR ASSEMBLY:
BILL OF MATERIALS &
LOCK RELEASE OPTIONS

NO.	DATE	REVISIONS
3	9/26/17	UPDATE TO 6TH ED. (2017) FBC
2	7/01/15	UPDATE TO 5TH ED. (2014) FBC
1	12/10/13	ADDED POROSITY D.P. RATING
		NO. DATE

DATE: 8/26/13
SCALE: N.T.S.
DWG. BY: JK
CHK. BY: LFS
DRAWING NO.: FL-10238.2
SHEET 12 OF 12